

An Adaptable Indoor Flight Test Implementation for small UAVs

Pengfei Yu*, Derrick Ho, and K.C Wong

The University of Sydney, Aeronautical Engineering Building, Sydney

ABSTRACT

In this paper, an adaptable indoor flight test implementation for small unmanned aerial vehicles (UAVs) with motion capture system (Mocap) is illustrated. By generating pulse position modulation (PPM) signals which conform to multi-protocol compatible radio control (RC) module, it enables control of commonly available commercial RC products which usually do not provide application program interface (API) to users. A PPM signal reader which receiving the exact same signal as the onboard receiver is constructed into the system to measure the signal latency, control signal loss and to retrieve the trim value for different manoeuvres of any specific aircraft. The implementation and results of commanded trajectories (circle, figure "8" and parabolic paths) were tested to explore the viability and adaptability of the presented method.

1 INTRODUCTION

Indoor testbeds for UAVs began to emerge nearly 12 years ago[1]. Progress in research has also excelled with the provision of Mocap system that provides highly accurate position and attitude feedback towards indoor testbeds such as aerial manipulation[2]–[5], aerobatics[6,7,8], coordinate construction[9,10] and others. By using the a Mocap system such as Vicon or Optitrack to provide accurate state space estimation for control, researchers can focus on higher level activity due to the control algorithm being

separated from state estimation. Researchers could get submillimeter accuracy with Mocap real-time streaming information even not fused with onboard sensors[11]. Examples of research approaches using Mocap include RAVEN from MIT[1], and the Flying Machine Arena from ETH[12]. Our test implementation has similar architecture on top level with the abovementioned setups. We extend this system architecture to adapt to both customized research platforms and commercial products which commonly use RC gear for control input. While the cost of Mocap systems is relatively high, it allows potential low-cost research on robot collaboration and swarm studies due to the low cost of commercial aerial platforms that can be as low as A\$22[13].

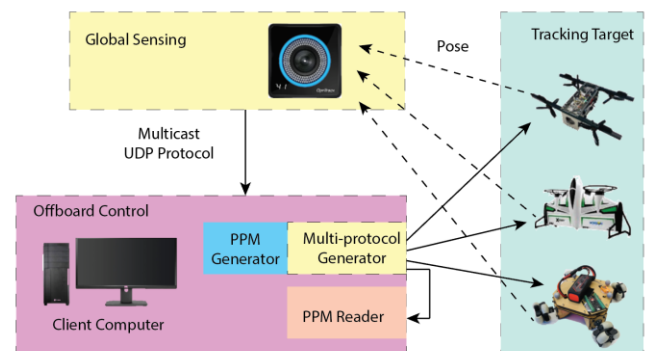

Figure 1- System Overview

By developing a PPM signal generator and reader, commercial products which do not offer APIs can be controlled using our implementation. By utilising the PPM signal reader, control output and input can be computed in a closed loop feedback system as seen in Figure 1. Researchers can then decipher the required PPM output towards controlling the commercial products, measuring

control command latency, loss of the command and get trim value of a specific state. With this methodology, the overall outcome allows researchers the ability to control a broad range of platforms and also reverse engineering the details with the PPM signals measuring.

This paper is organised as follows: Section 2 presents overview of system setup and performance. Section 3 shows test result from our customized research platform and commercial products. Section 4 provides summary and future work.

2 SYSTEM OVERVIEWS

Mocap systems provide global sensing of the objects position and orientation and offboard computer offer extra computational power to process the information; typically with high computational control algorithm to traverse mobile platforms. The general data flow of our implementation is illustrated in Figure 1: pose of target is estimated by software running on a host machine from Mocap system. This host machine broadcasts the estimation through UDP protocol and any client machine in the same network with host machine can access these state estimations simultaneously with other clients and use it in their own applications such as specific control algorithms. Control commands are generated through a PPM signal generator to a multi-protocol transmitter module. For typical usage, command signals would be sent to the receiver on target UAVs and a separated receiver connected to a PPM signal reader which send back the actual received command information to offboard computer to calculate command latency, command loss and get a trim value of specific state.

2.1 Hardware for global sensing

Hardware includes two parts. Part one is for global sensing and part two is for offboard control.

The hardware for global sensing in our setup includes the following in Table 1:

| Component | Part | Detail |
|-----------|------------------------|---|
| Camera | Optirack 41W | 4.1MP Horizontal FOV 51° |
| | Optirack 17W | 1.7MP Horizontal FOV 70° |
| Host | Computer Windows OS | CPU: Intel CoreI7-6700K NIC: Intel E1G42ETBLK Dual Port Adapter |
| Network | Wi-Fi Router | TY-LINK ARCHER AR2600 |
| Software | Motive 2.0 | |

Table 1 - Hardware for Global Sensing

The Mocap system software (Motive) is running on Windows operating system. The host machine is connected to a WIFI router which could provide a stable network connection to client machine through WIFI or Ethernet cable. The system is capable of transmitting information at the rate of over 200Hz, however typical 180Hz is used.

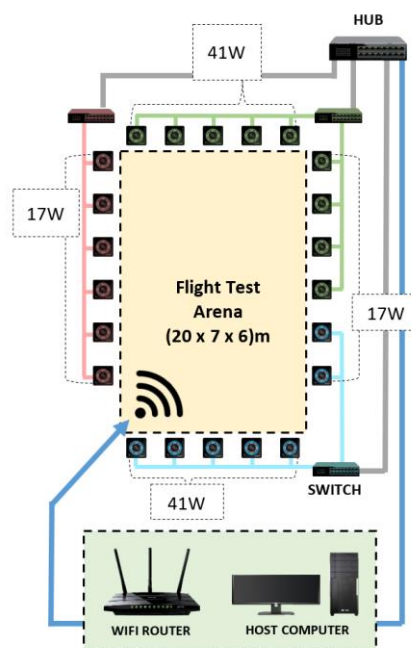

Figure 2 - Hardware for global sensing

A rigid body consisting of 3 or more reflective markers allows tracking of position and orientation. For single marker target, only position can be tracked. All estimated state is relative to user defined coordinate. The latency from the Optitrack software to achieve global sensing is approximately 5ms. The UAV-Lab flight test arena offers a 140m² (20m×7m×6m) useable volume which could potentially be utilized for flight testing small and slow fixed-wing or small vertical take-off and landing (VTOL) aircraft in fixed-wing mode. With this setup, the effective detectable range for a marker size of 3-4 cm is approximately 23m and therefore the whole volume is capable and effective towards detecting the markers. Increasing the brightness threshold for marker detection yields higher reliability due to eliminating sources of low reflectivity (or otherwise noise towards markers due to unwanted reflections).

2.2 Hardware for offboard control

Our hardware for offboard control include a PPM signal generator, a multi-protocol RC module (Figure 3) and a PPM signal reader shown in Figure 5. A PPM signal is generated conforming to the multi-protocol RC module. This allows the user to manipulate and orchestrate the output of the UAV by constructing the correct length of pulses within the PPM signal. In lieu of this, and in conjunction with the multi-protocol transmitter module, this ideology can therefore adapt to DSMX, DSM2 (Spectrum), D8, AFHDS (Frsky), FASST (Futaba), A-FHSS (Hitec) as popular RC-protocol examples. As it includes most main stream protocols provided on the current market, which makes it adaptable to a majority of the off-the-shelf product which allows a broad selection of platforms to be acquired and tested. For instance, we could adapt to control mini quadrotor (Eachine E010[13]) costing A\$20 to higher calibre VTOL UAV aircraft such as a X-Vert or any other commercial ones, provided it uses a common RC protocol. Noteworthy when using

multiprotocol modules, it needs to bind to the same protocol (a compatible) receiver in the traditional RC way; typically, through a transmitter that supports external radio modules such as a FrSky Taranis XD9 as one example.



Figure 3 - Multi-protocol Module[14]

In a PPM signal frame (Figure 4), each channel maps a certain controller output from 1000 (1ms) to 2000 (2ms). Each channel is separated by a small-time gap (0.4ms). The total frame length of the signal is 22.5ms for an 8 channels PPM command.

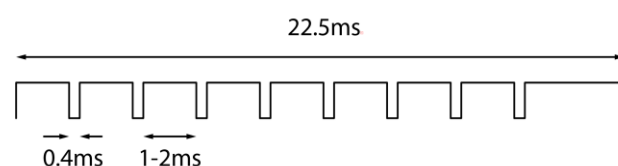

Figure 4 - PPM Signal (8 channels)

PPM reader assumes that two identical receivers which both bind to the same transmitter module receives the radio signal at the same time. Like the way that researchers construct satellite receiver configuration to have better access to the radio signal and provide extra redundancy in the system. Under this assumption, the PPM reader is employed to measure the latency of when the radio command is received between the transmitter and receiver. Similarly, the PPM reader can also be used to record the pilot controls during manual UAV flying operation from a transmitter by logging the PPM signal to determine the intended control inputs. It is also a helpful feature which could help to find out the

trim value for certain state of the test aircraft; e.g. hover trim values of a VTOL UAV.

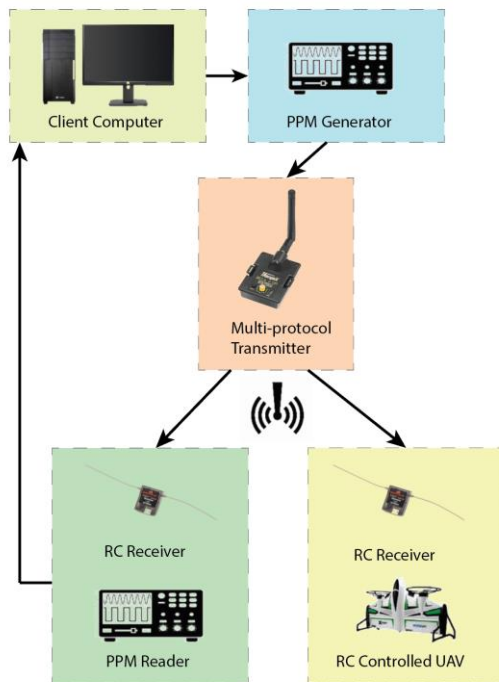

Figure 5 - Hardware for offboard control

2.3 Latency

System latency comes from mainly three sources:

- (1) Mocap system capture latency;
- (2) PPM signal generating time;
- (3) radio signal decoding latency;

Figure 6 shows the system latency in average which can accumulate to 50ms on average based on methods described later. Note our method is one direction only, and it also has variable latency.

For small size UAV such as crazyflie which is also a 22g mini quadrotor, motor response time could be as high as 200-300ms[15], which is significantly higher than the aforementioned system latency. So, in term of real world response time, the dominated term is still the mechanical time constant.

In Figure 7, blue line is the PPM signal sent with its timestamp and red line is PPM signal received with its timestamp. X axis is system time, unit is

second. Y axis is the sweep signal which ranges from 1000 to 1900.

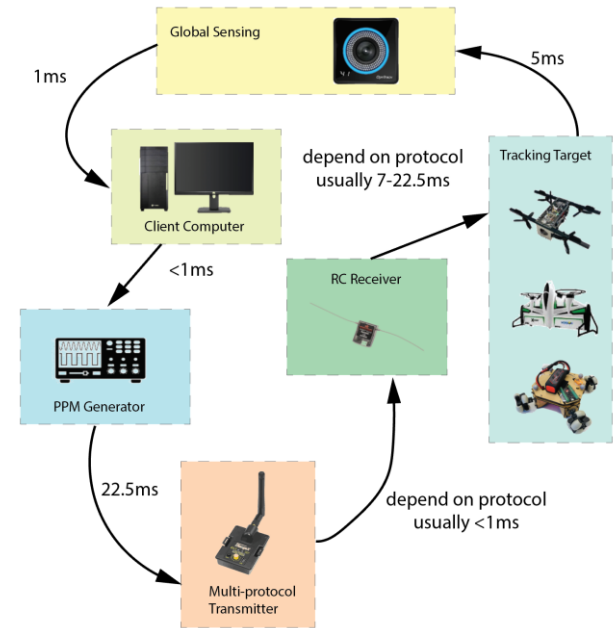

Figure 6 - System latency

The setup detail is that a PPM generator generates a known pattern of signal numbers from 1000 to 1900 to conform to typical RC pulse width ranges, which is then transmitted by the multiprotocol transmitter module. The RC receiver receives the signal numbers and log the time it collects the signal numbers and sends it back to user's computer. System latency could be measured by comparing the time difference between when it is transmitted and received.

The receiver relies on the protocol that is used. Certain protocol such as SBUS has significantly lower latency compared to other protocols.

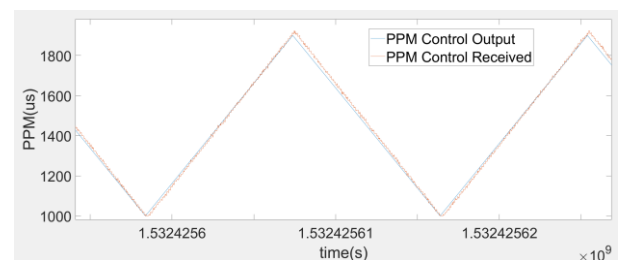

Figure 7-Measured latency

2.4 Logging and Failsafe

One benefit of using Multi-protocol module is that researchers could mount this module onto a commercial transmitter. By setting up the trainer port on a commercial transmitter, researchers could switch back to manual control whenever there is something unexpected happen via flipping trainer switch.

Note that if you use commercial transmitter as a failsafe method, dual-rate, exponential function and trim values should all be reset to avoid interfering and undesired adjustments of the PPM command that is intended to be transmitted.

In summary, all desired pose, actual pose, command sent, and command received are logged in the client computer which allows researchers to plot, analyse and replay all information for further analysis.

3 FLIGHT TESTS

3.1 Test platform

Two test platforms are chosen:(1) Mini 22g QX65 quadrotor by Eachine, and (2) A 210g fixed-wing VTOL aircraft capable of forward flight; X-Vert by E-flite.

The mini quadrotor allows basic testing due to its inherent stability provided by the manufacture while the fixed-wing UAV offers the ability to conduct forward flight testing in future aerodynamic flight control phases.

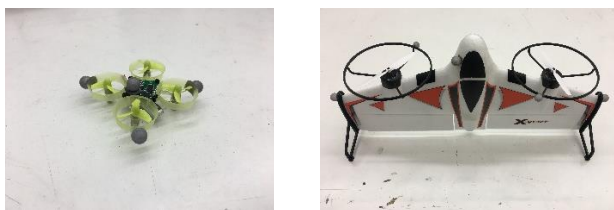

Figure 8 - QX65 and X-Vert with makers

3.2 Controller Diagram

Our controller follows traditional cascaded control methodology for multicopter (Figure 9). In our

case, the onboard attitude controllers are employed for overall flight stabilisation. Customized PID position controller is running on offboard computer at 50Hz. The desired position of vehicle in world frame is r_t , actual position is r , and acceleration is \ddot{r} .

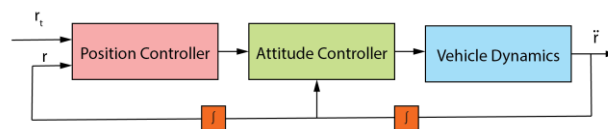

Figure 9 - Control Diagram

3.3 Experiment results

Vehicles are controlled to follow trajectories of a circle, a figure "8" and a parabola. Here are the results of these tests. These tests illustrate that current implementation could effectively track desired trajectory as they are shown in Figure 10 and 11.

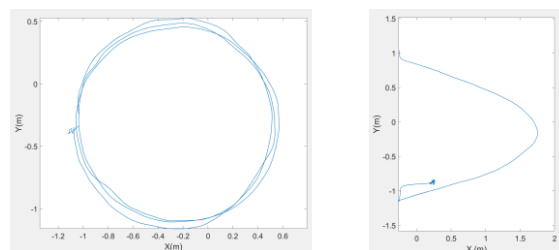

Figure 10 - Circle and Parabola

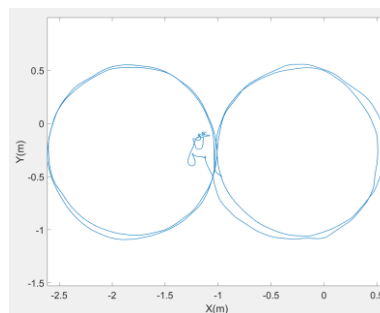

Figure 11 - Figure "8"

4 CONCLUSIONS AND FUTURE WORKS

In this paper, we have introduced a practical implementation for indoor UAV flight testing under closed-loop control with the assistance of Mocap system and multi-protocol modules. The benefit of this method is that it could adapt to a

variety of platforms including not only customized but also commercial available RC UAV with the ability to quantify latency. By constructing a PPM signal reader into the system, users could also monitor the variable latency, loss of command signal and get a trim value for the specific state. Test video of this paper is available on YouTube: <https://youtu.be/fV1l--NOZWM>.

REFERENCES

- [1] J. P. How *et al.*, "Real-time indoor autonomous vehicle test environment," *IEEE Control Syst. Mag.*, vol. 28, no. 2, pp. 51–64, Apr. 2008.
- [2] P. E. I. Pounds, D. R. Bersak, and A. M. Dollar, "Grasping from the air: Hovering capture and load stability," in *IEEE International Conference on Robotics and Automation*, 2011, pp. 2491–2498.
- [3] F. Huber *et al.*, "First analysis and experiments in aerial manipulation using fully actuated redundant robot arm," *IEEE Int. Conf. Intell. Robot. Syst.*, pp. 3452–3457, 2013.
- [4] A. Torre, D. Mengoli, R. Naldi, F. Forte, A. Macchelli, and L. Marconi, "A prototype of aerial manipulator," in *IEEE/RSJ International Conference on Intelligent Robots and Systems*, 2012, pp. 2653–2654.
- [5] A. Q. L. Keemink, M. Fumagalli, S. Stramigioli, and R. Carloni, "Mechanical design of a manipulation system for unmanned aerial vehicles," in *IEEE International Conference on Robotics and Automation*, 2012, pp. 3147–3152.
- [6] S. Lupashin *et al.*, "A simple learning strategy for high-speed quadcopter multi-flips," in *2010 IEEE International Conference on Robotics and Automation*, 2010, pp. 1642–1648.
- [7] M. Hehn and R. D'Andrea, "A flying inverted pendulum," in *2011 IEEE International Conference on Robotics and Automation*, 2011, pp. 763–770.
- [8] D. Brescianini, M. Hehn, and R. D'Andrea, "Quadcopter pole acrobatics," in *2013 IEEE/RSJ International Conference on Intelligent Robots and Systems*, 2013, pp. 3472–3479.
- [9] F. Augugliaro, E. Zarfati, A. Mirjan, and R. D'Andrea, "Knot-tying with flying machines for aerial construction," in *2015 IEEE/RSJ International Conference on Intelligent Robots and Systems (IROS)*, 2015, pp. 5917–5922.
- [10] F. Augugliaro *et al.*, "The flight assembled architecture installation: Cooperative construction with flying machines," *IEEE Control Syst.*, vol. 34, no. 4, pp. 46–64, 2014.
- [11] D. Mellinger, "Trajectory Generation and Control for Quadrotors," *PhD*, 2012.
- [12] S. Lupashin, M. Hehn, M. W. Mueller, A. P. Schoellig, M. Sherback, and R. D'Andrea, "A platform for aerial robotics research and demonstration: The Flying Machine Arena," *Mechatronics*, vol. 24, no. 1, pp. 41–54, 2014.
- [13] "Eachine E010." [Online]. Available: https://www.banggood.com/Eachine-E010-Mini-2_4G-4CH-6-Axis-Headless-Mode-RC-Quadcopter-RTF-p-1066972.html?rmmids=search&cur_warehouse=AU.
- [14] "Multi-protocol Module." [Online]. Available: https://hobbyking.com/en_us/jumper-jp4in1-multi-protocol-radio-transmitter-module.html.
- [15] Y. Chen and N. O. Perez-Arancibia, "Generation and real-time implementation of high-speed controlled maneuvers using an autonomous 19-gram quadrotor," in *2016 IEEE International Conference on Robotics and Automation (ICRA)*, 2016, pp. 3204–3211.